

Remove screws (# 55 page 38) (B) holding the upper and lower housings (# 63 page 38) together, including the two lower screws (C) in speed changer bracket just below the speed dial.

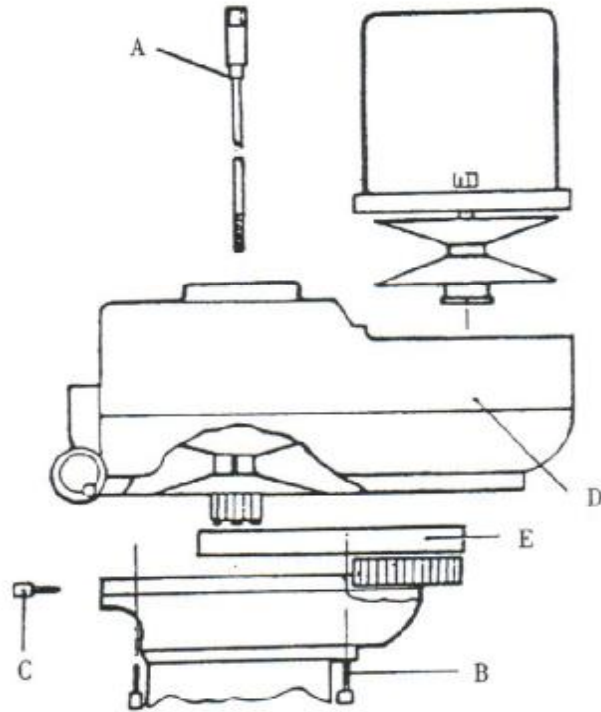

Figure 12. Removing Timing Belt

A slight blow under the speed changer bracket (# 5 page 36) may be needed to separate the upper housing (D) from its base.

As the housings are being separated, the HTD belt (D) (# 36 pag 36) still connects them, resisting the separation movement. The separation can be assisted by gently pushing the belt off the large pulley (# 86 page 36) as the upper housing is being raised.

Remove the old belt and replace with a new belt.

GENERAL SPEED RECOMMENDATIONS

Material to be Cut	Feet Per Minute		
	Rough	Rough and	Light and
	Cut	Finish	Finish Cut
Cast Iron Soft. (Under 200 Brinnell)	70	80.90	120
Cast Iron, Med. (200.300 Brinnell)	55	60.70	90
Cast Iron, Hard. (Over 200 Brinnell)	40	50.60	70
Steel(Chrome Nickel 40 - 45 Shore)	30	40	50
Steel(Stainless)	60	80	90
Steel(Low Carbon)	80	90	140
Steel(High Carbon)	40	50	70
Bronze(Medium)	90	120	150
Bronze(Hard)	65	90	130
Brass(Hard)	100	150	200
Copper	150	200	300
Duraluminum	400	...	600
Aluminum	600	...	1000

TABLE OF CUTTING SPEEDS AND FEEDS

Feet Per Minute	15	20	25	30	40	50	60	70	80	90	100
Diameter, Inches	Revolutions Per Minute										
1/16"	917	1222	1528	1833	2445	3056	3667	4278	4889	5500	6112
1/8"	458	611	764	917	1222	1528	1833	2139	2445	2750	3056
3/16"	306	407	509	611	815	1019	1222	1426	1630	1833	2037
1/4"	229	306	382	458	611	764	917	1070	1375	1375	1528
5/16"	183	244	306	367	489	611	733	856	978	1100	1222
3/8"	153	204	255	306	407	509	611	713	815	917	1019
7/16"	131	175	218	262	349	437	524	611	698	786	873
1/2"	115	153	191	229	306	382	458	535	611	688	764
5/8"	91	122	153	183	244	306	367	428	489	550	611
3/4"	76	102	127	153	204	255	306	357	407	458	509
7/8"	65	87	109	131	175	218	262	306	349	393	437
1"	57	76	95	115	153	191	229	267	306	344	382
1 1/8"	50	67	84	102	136	170	204	238	272	306	340
1 1/4"	45	61	76	91	122	153	183	214	244	275	306
1 3/8"	41	55	69	83	111	139	167	194	222	250	278
1 1/2"	38	50	63	76	102	127	153	178	204	229	255
1 5/8"	35	47	58	70	94	118	141	165	188	212	235
1 3/4"	32	43	54	65	87	109	131	153	175	196	218
1 7/8"	30	40	50	61	81	102	122	143	163	183	204
2"	28	38	47	57	76	95	115	134	153	172	191

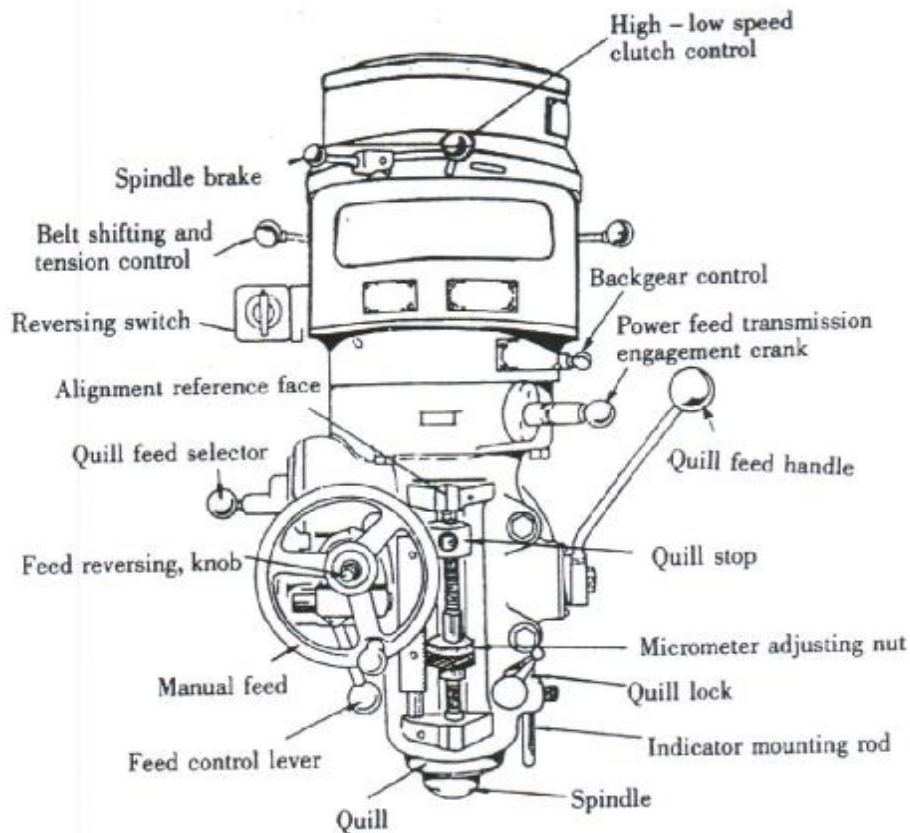

- (1) **REVERSING SWITCH** is used to obtain clockwise or counter clockwise rotation of spindle.
 Note: Due to back gear construction, When machine is running in low speed range, spindle rotation is opposite to that of high speed range. Therefore forward on your reversing switch becomes reverse switch in low speed range.
- (2) **SPINDLE BRAKE**
 Lever can be moved in either direction to stop spindle; however, when locking spindle, lever should be moved to right or left and the raised.
CAUTION: Be certain that the spindle brake is released before starting the motor. This is important as the motor can be damaged if switch is left on with brake in locked position.
- (3) **HIGH LOW SPEED CLUTCH CONTROL** is directly in front of motor. When knob is in position, as shown on picture, clutch is in high speed position. To put clutch into low speed position turn lever to the extreme right. It is necessary to rotate spindle while engaging high speed clutch. This can be accomplished by either turning spindle nose by hand or by turning drawbar knob using wrench, providing drawbar is pulled up tightly.
CAUTION: Do not shift clutch while motor is running.
- (4) **BACK GEAR CONTROL** is used in conjunction with the high low speed clutch control above back gear control handle is stamped IN and OUT. when back gear control handle is in OUT position, which is the position furthest from face of machine. Then HIGH LOW speed clutch control should be located as illustrated in photograph. With these controls in position as explained, head is set for operation in high speed range (660 - 2720 RPM). When back gear control lever moved to IN position and HIGH LOW speed clutch control moved to extreme right then the head is ready for operation in the low speed range (80 - 325 RPM).

BASIC MACHINE

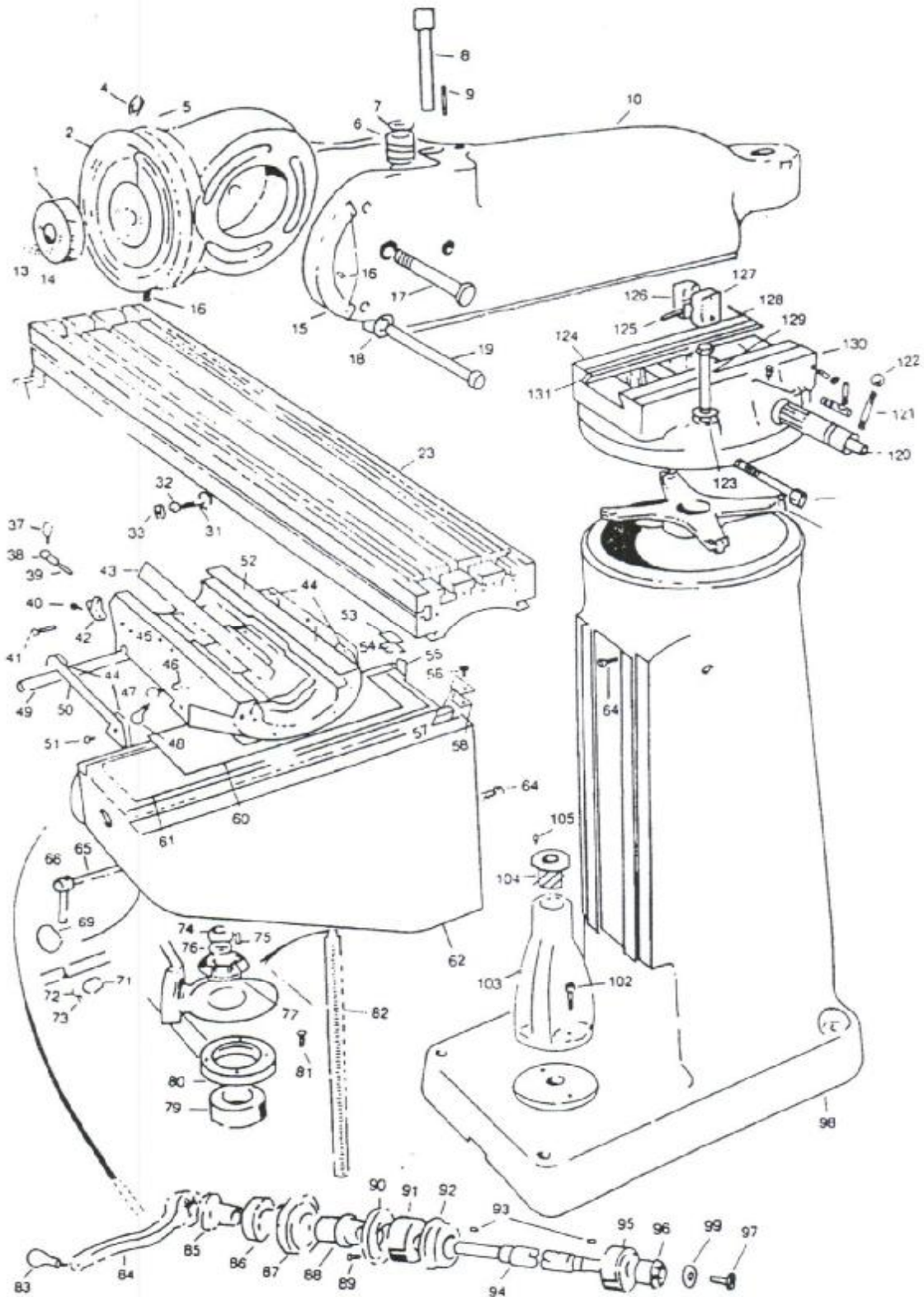

BASIC MACHINE

ITEM NO.	PARTS NO.	DESCRIPTION	ITEM NO.	PARTS NO.	DESCRIPTION
1	5033	Quill Housing ADJ. Gear	69	4001 - 1	Knee Lock Plunger
2	5019	Ram Adapter	71	4045	Knee Binder Plug(plastic)
4	5027	Nut	72	4049	Dog Point Set Screw
6	5020	Vertical Adjusting Worm	73	4049	Set Screw
7	5022	Worm Thrust Washer(2Req)	74	4023	Jam Nut
8	5021	Vertical Adjusting Worm Shaft	75	4020	Key
9	5023	Worm key	76	4022	Washer
10	5018	Ram	77	4019	Bevel Gear
13	5035	Socket Cap Screw(2 Req.)	79	4040	Sealed Ball Bearing
14	5034	Roll Dowel Pin	80	4039	Bearing Retainer Ring
15	5043	Angle Plate	81	4041	Socket Head Cap Screw
16	5032	Round HD Drive Screw(5 Req.)	82	4021	Elevating Screw Assembly
17	5026	Adapter Pivot Pin	83	4003	Handle
18	5029	Chamfered & Hardened washer (7 Req.)	84	4002	Elevating Crank
19	5028	Adapter Locking Bolt(3 Req.)	85	4013	Gearshaft Clutch Insert
23	2001	Table 42" or 49"	86	2016	Dial Lock Nut
			87	4010	Dial with 100 Graduations
			88	4011	Dial Holder
31	2031	Stop Piece T - Bolt(3 Req.)	89	4009	Socket Head Cap Screw
32	2030	Table Stop Piece(2 Req.)	90	2011	Bearing Retaining Ring
33	2032	Hex Nut(3 Req.)	91	4007	Grease Sealed Bearing
37	3031	Table Lock Bolt Handle	92	4006	Bearing Cap
38	3030	Saddle Lock Bolt	93	4015	Key
39	3032	Saddle Lock Plunger	94	4017	Elevating Shaft for 12"Knee
40	3036	Socket HD cap Screw(2 Req.)	95	4016	Grease Sealed Bearing
41	3028	Gib Adjusting Screw(3 Req.)	96	4014	Bevel Pinion
42	3035	Table Stop Bracket	97	4042	Set Screw
43	3026	Saddle Table Gib Stop Bracket	98	1001	Column
44	3037	Felt Wipers (4 Req.)	99	4017 - 1	Washer
46	3029	Table Lock Plunger	102	4027	Socket Head Cap screw
47	3030	Table Lock Bolt	103	4026	Pedestal
48	3031	Table Lock Bolt Handle	104	4024	Elevating Screw Nut
49	3027	Saddle/Knee Gib	105	4025	Socket Head Cap Screw
50	3037 - 2	Saddle Knee Wiper Plate(4 Req.)	118	5003	Spider
51	3038	Oval Head Screw(8 Req.)	119	5009 - 1	Ram Lock Stud
52	3001	Saddle	120	5012	Ram Pinion
53	4028 - 2	Left Hand Column Wiper Holder	121	5013	Ram Pinion Handle
54	4028 - 1	Knee Wiper Felt	122	5014	Plastic Ball
55	4038	Knee/Column Gib	123	5005	Chamfered x Hardened Washer
56	4029	Allen Cap Screw(2 Req.)	124	5001	Turret
57	4028 - 2	Right Hand Column Wiper Holder	125	5002 - 3	Ram CLamp Bar
58	4028	Knee Wiper Felt	126	5002 - 1	Ram Clamp Untapped
60	3040	Chip Guards - Upper	127	5002 - 2	Ram Clamp Tapped
61	3039	Chip Guards - Lower	128	5002 - 4	Split Pin
62	4001	Knee 12"	129	5004	Locking Bolt
64	1001 - 1	Stop Screw	130	5015	Ram Pinion Screw
65	4048	Knee Lock Shaft Assembly	131	5002	Ram/Turret Gib

LEADSCREW ASSEMBLY

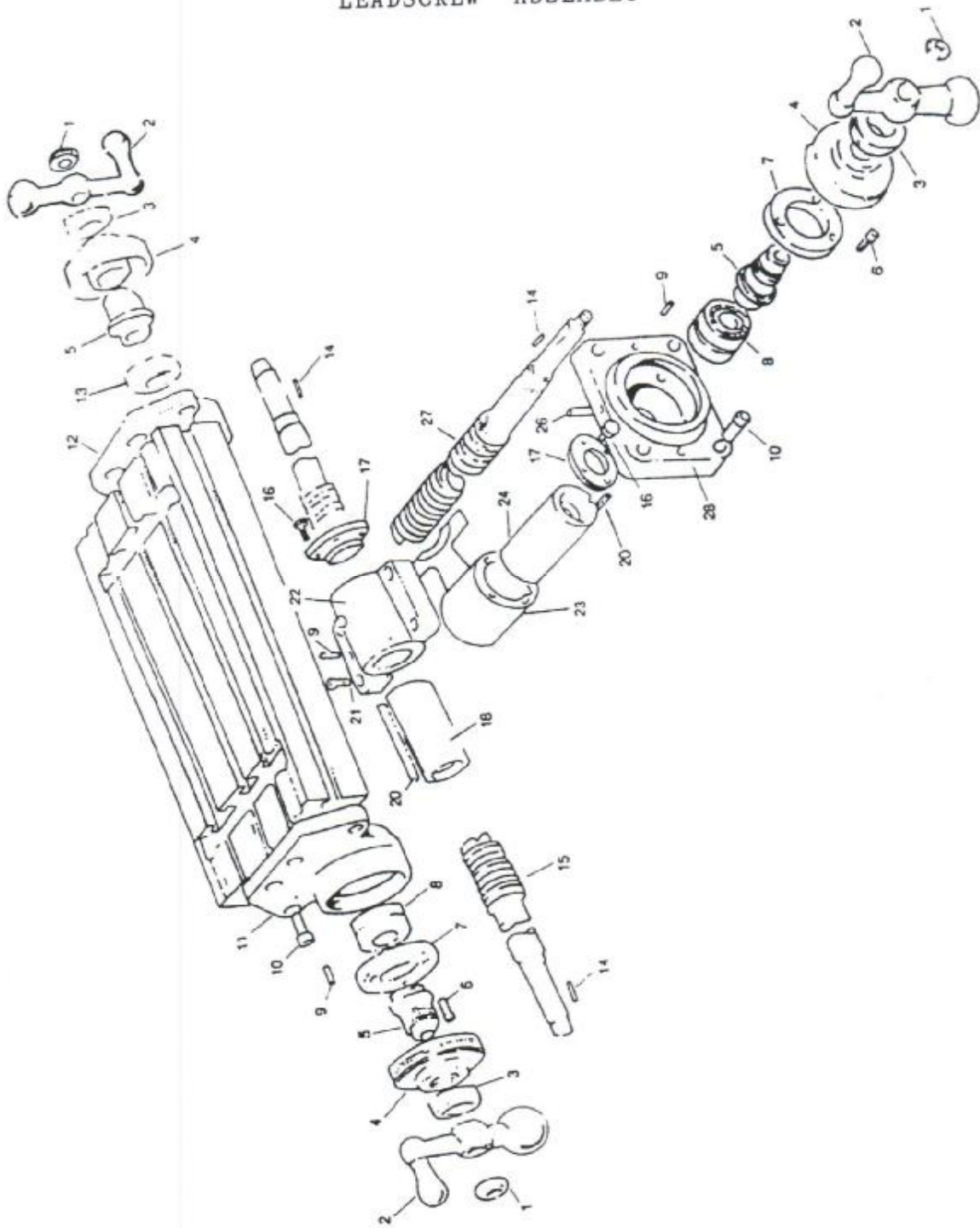

LEADSCREW ASSEMBLY

ITEM NO.	PARTS NO.	DESCRIPTION
1	2004	Jam Nut(3 Req.)
2	2018	Ball Crand Handle (3 Req.)
3	2004	Dial Lock Nut(3 Req.)
4	2012	Dial with 200 Graduations (3 Req.)
5	2014	Dial Holder(3 Req.)
6	2036	Socket Cap Scerew(6 Req.)
7	2011	Bearing Retainer Ring(2 Req.)
8	2008	Gerase Sealed Ball Bearings(2 Req.)
9	2027	Roll Pin(10 Req.)
10	2026	Socket Cap Screw(12 Req.)
11	2006	Left Bearing Bracket
12	2006	Right Bearing Bracket
13	2008	Grease Seal Ball Bearing
14	2003	Key(3 Req.)
15	3002	Longitudinal Feed Screw 42" or 49"
16	3021	Socket Cap Screw(8 Req.)
17	3019	Gross Feed Nut Retaining Plate(2 Req.)
18	3020	Longitudinal Feed Nut
20	3041	Key(2 Req.)
21	3024	Socket Cap Screw (8 Req.)
22	3023	Longitudinal Feed Nut Bracket
23	3022	Cross Feed Nut Bracket
24	3020	Cross Feed Nut
26	3005 - 1	Stop Screw
27	3002	Cross Feed Screw For 12" Knee
28	3005	Cross Feed Bearing Bracket

HEAD PARTS LIST

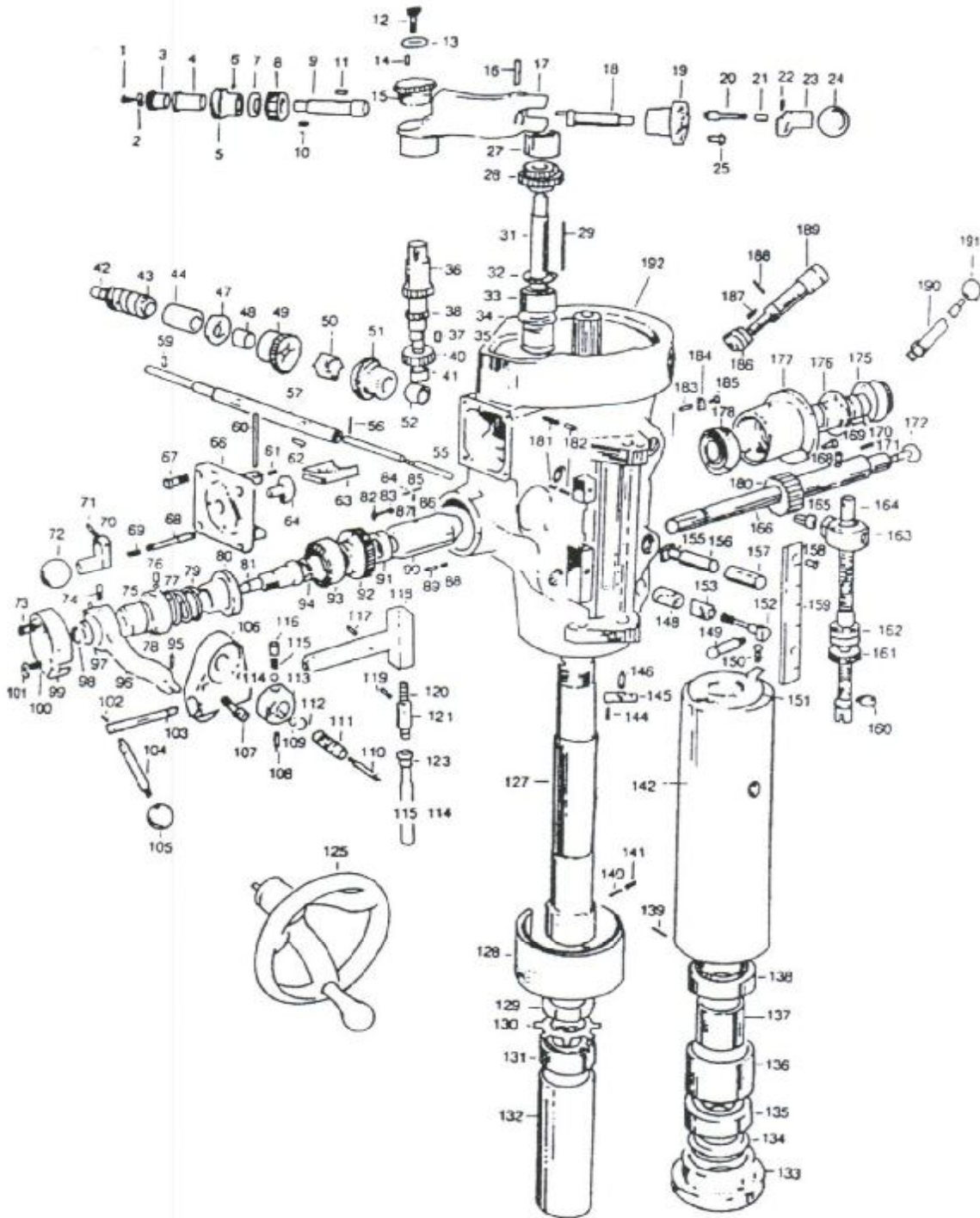

HEAD PARTS LIST

ITEM NO.	PARTS NO.	DESCRIPTION	ITEM NO.	PARTS NO.	DESCRIPTION
1	6141	RD. HD. Screw	61	6164	KP. Set Screw
2	6140	Bevel Pinion Washer	62	6230	Key
3	6139	Feed Bevel Pinion	63	6162	Feed Gear Shift Crank
4	6138	Feed Worm Gear Shaft Sleeve	64	6166	Cluster Gear Shift Crank
5	6137	Worm Cradle Bushing	66	6161	Cluster Gear Cover
6	6123	Setscrew	67	6165	Cap Screw(4 Req.)
7	6136	Worm Cradle Spacer(4 Req.)	68	6169	Gear Shift Plunger
8	6134	Feed drive Worm Gear	69	6170	Compression Spring
9	6133	Feed Drive Worm Gear Shaft	70	6168	Shift Crank
10	6142	Worm Shaft Key	71	6167	Roll Pin
11	6135	Key	72	6171	Black Plastic Ball
12	6150	Locknut	73	6206	Cap Screw(2 Req.)
13	6149	Washer	74	6202	Clutch Ring Pin(2 Req.)
14	6147	Cluster Gear Key	75	6200	Clutch Ring
15	6148	Feed Reverse Bevel Gear	76	6199	Socket Set Screw
16	6122	feed Engage Pin	77	6199 - 1	Brass Plug
17	6121	Worm Gear Cradle	78	6198	Overload Clutch Locknut
18	6126	Worm Gear Cradle Throw - out	79	6197	Safety Clutch Spring
19	6125	Shift Sleeve	80	6194	Overload Clutch
20	6169	Gearshift Plunger	81	6195	Overload Clutch Sleeve
21	6170	Compression Spring	82	6190	Single Spring Washer(3 Req.)
22	6128	Roll Pin	83	6189	Round Head Screw(3 Req.)
23	6168	Shift Crank	84	6228	Mock - it Lockscrew
24	6131	Black Plastic Ball	85	6228	Socket Set Screw
25	6132	Cap Screw(3 Req.)	86	6246	Lockscrew
27	6157	Cluster Gear Shaft Upprer Bearing	87	6246 - 1	Socket Set Screw
28	6153	Cluster Gears Assembly	88	6191	Compression Spring
29	6160	Cluster Gear Key	89	6193	Overload Clutch Lever Spring Plunger
31	6151	Clustser Gear Shaft	90	6186	Quil Pinion Shaft Bushing
32	6158	Snap Ring	91	6190	Pinion Shaft Worm Gear Spacer
33	6156	Bevel Gear Bearing	92	6187	Overload Clutch Worm Gear
34	6159	Bevel Gear Thrust Spacer	93	6188	Overload Clutch Ring
35	6151	Feed Reverse Bevel Pinion	94	6188 - 1	Snap Ring
36	6143	Feed Driving Gear	95	6236 - 1	Dowel Pin
37	6145	Key	96	6203	Overload Clutch Trip Lever
38	6143	Cluster Gear Input Shaft	97	6201	Overload Clutch WASHER
40	6144	Feed Drive Gear	98	6195 - 1	Snap Ring
41	6252	Needle Bearing	99	6205	Clutch Arm Cover
42	6227	Bushing	100	6207	Socket Set Screw
43	6225	Worm	101	6208	Chem Blacket Locknut
44	6224	Feed Worm Shaft Bushing	103	6239	Cam Rod
47	6223	Feed Worm Shaft Thrust Washer	104	6234	Trip Handle
48	6220	Bushing	105	6233	Black Plastic Ball
49	6220	Feed Reverse Bevel Gear	106	6231	Feed Trip Bracket
50	6222	Feed Teverse Clutch	107	6232	Cap Screw(2 Req.)
51	6220	Feed Reverse Bevel Gear	108	6219	Socket Set Screw
52	6220	Bushing	109	6229	Key
55	6216	Reverse Clutch Rod	110	6214	Feed Reverse Knob Stud
56	6217	Roll Pin	111	6213	Reverse Knob
57	6209	Feed worm Shaft	112	6215	Snap Ring
59	6226	Pin	113	6218	Handwheel Clutch
60	6163	Feed Shaft Rod	114	6255	Steel Ball

HEAD PARTS LIST(CONTINUED)

ITEM NO.	PARTS NO.	DESCRIPTION	ITEM NO.	PARTS NO.	DESCRIPTION
115	6219 - 2	Compression spring	158	6244	Chem Blacked RD. HD. Screws (2 Req.)
116	6219 - 1	Handwheel Clutch Spring Screw	159	6243	Micrometer Scale
117	6237	Roll Pin	160	6115	Snap Ring
118	6236	Cam Rod Sleeve Assy	161	6108	Quill Micro - stop Nut
119	6241	Roll Pin	162	6107	Micrometer Nut
120	6242	Compression Spring	163	6105	Quill Stop Knob
121	6240	Trip Plunger	164	6104	Quill Stop Micro - screw
123	6118 - 1	Trip Plunger Bushing	165	6106	Screw
124	6118	Feed Trip Plunger	166	6172	Quill Pinion Shaft
125	6210	Handwheel	168	6185	Spring Pin
127	6084	Spindle	169	6180 - 1	RD. Head Scrw(2 Req.)
128	6086	Quill Skirt	170	6179	Roll Pin
129	6090	Locknut	171	6184	Key
130	6091	Lockwasher	172	6183	Pinion Shaft Hub Screw
131	6092	Bearing	173	6176	Steel Ball
132	6094	Sleeve	174	6175	Compression Spring
133	6098	Nose - piece	175	6178	Rack Feed Handle Hub
134	6097	Spindle Dirt Shield	176	6182	Pinion Shaft Hub Sleeve
135	6093	Bearing	177	6180	Spring Vover
136	6095	(Bearing Spacer - Large)	178	6181	Clock Spring(Clock Spring Assy.) Assy.)
137	6096	(Bearing Spacer - Small)	180	6172	Quill Pinion
138	6093	Bearing	181	6246 - 1	Socket Set Screw
140	6253	Special Socket Set Screw	182	6246	Lockscrew
141	6254	Collet Alignment Screw	183	6110	Reverse Trip Ball Lever
142	6085	Quill	184	6109	Feed Reverse Trip Plunger
144	6113	Socket Set Screw	185	6114	Raverse/Trip Ball Lever Screw
145	6111	Feed Trip Lever	186	5039	Worm Gear
146	6112	Trip Lever Pin	187	5041	Key
148	6116	Quill Lock Sleeve	188	5042	Socket Set Screw
149	6119	Lock Handle	189	5040	ADJ Worm Shaft
151	6088	Felt Washer	190	6174	Pinion Shaft Hub Handle
152	6117	Quick Lock Bolt	191	6173	Black Plastic Ball Handles
153	6116	Quill Lock Sleeve Tapped	192	6101	Quill Housing
155	5036	T - Blot Assy			
156	6120	Lower Clamping Blot Spacer(2 req)			
157	5038	Locknut			

VARIABLE SPEED HEAD TOP HOUSING

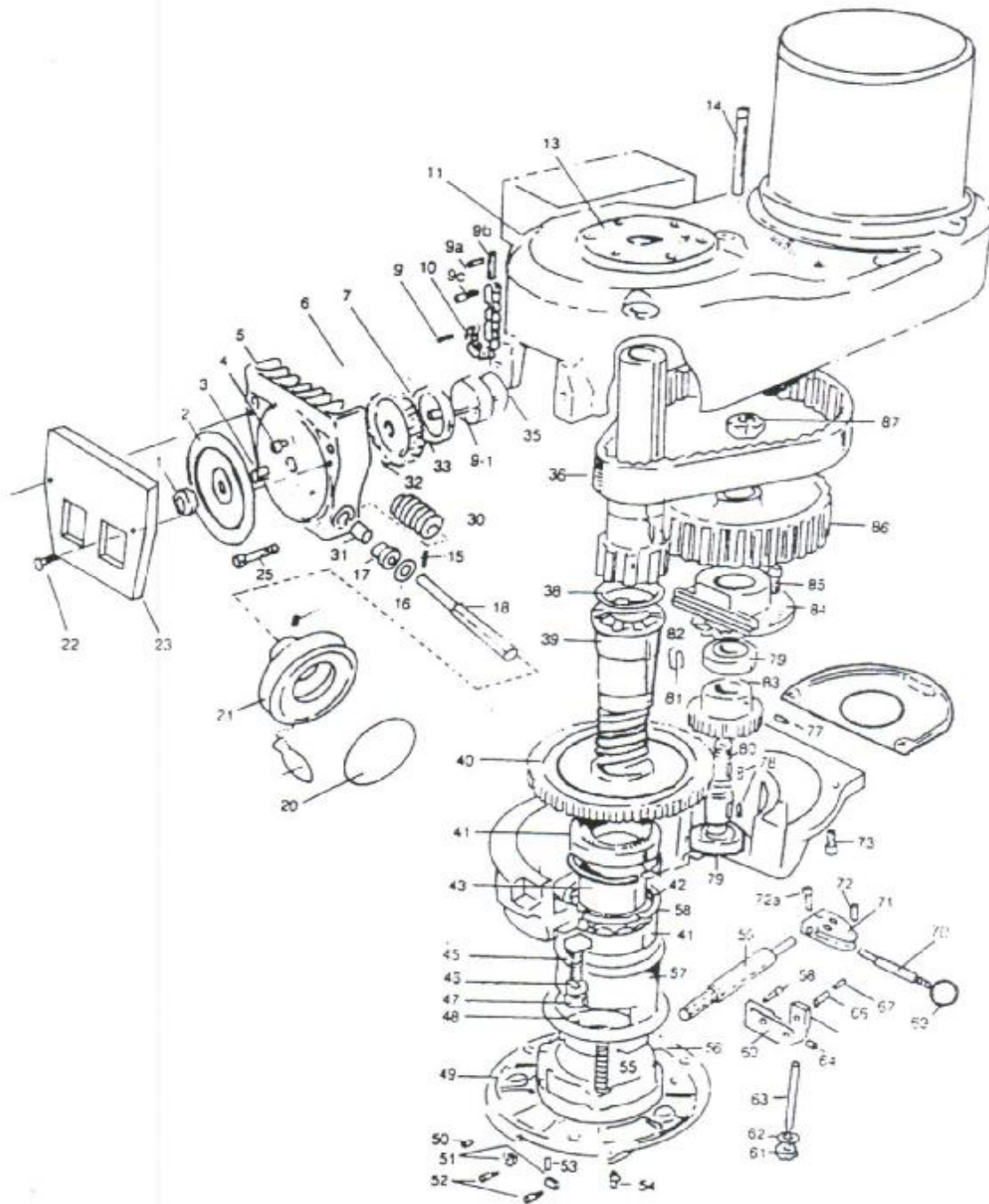

VARIABLE SPEED HEAD TOP HOUSING

ITEM NO.	DESCRIPTION	ITEM NO.	DESCRIPTION
1	Hex Cap Nut	47	Hex Jam Nut - Finished HdN:(3 Req.)
2	Vari - Speed Dial	48	Ball Bearing Gear Sleeve Washer
3	Bronze Bearing	49	Fixed Clutch Bracket
4	Full Dog Socket Set Screw	50	Socket Set Screw
5	Speed Changer Housing	51	Guide for Clutch Bracket
6	Speed Changer Chip Shield	52	Flat HD Socket Cap Screw(2 Req.)
7	Machine Screws(2 Req.)	53	Dowel Pin
9	Roll Pin	54	Oil Cup
9 - 1	Roll Pin	55	Compression spring(3 Req.)
9a	Roll Pin	56	Bearing Locknut
9b	Speed Change Stud	57	Bearing Sleeve
9c	Cotter Pin	58	Wave Spring Washer
10	Speed Changer Chain	59	Bull Gear Shift Pinion
11	Drum Switch	60	HI - LOW Detent Plate
13	Top Bearing Cap	61	Hex Nut(3 Req.)
14	Soc HD Cap Screw(2 Req.)	62	Lock Washer(3 Req.)
15	Roll Pin	63	Studs(3 Req.)
16	Spring	64	Socket Set Screw
17	Bearing	65	Adjustable Plate
18	Speed Change Shaft	66	HI - LOW Detent Plunger
19	Handle	67	Spring
20	Caution Plate	68	Socket Cap Screw(2 Req.)
21	Speed Change Handwheel	69	Bakelite Ball Handle
22	Flat Hd. Cap Screw(2 Req.)	70	HI - LOW Shift Crank
23	Plastic Face Plate	71	HI - LOW Pinion Block
24	Set Screw	72	Roll Pin(1 Req.)
25	Socket HD Cap Screw(4 Req.)	72a	Socket HD Cap Screw(2 Req.)
30	Worm Gear	73	Socket Cap Screw(4 Req.)
31	Bearing	77	Socket Set Screw
33	Speed Changer Spur Gear	78	Key(2 Req.)
35	Speed Change Chain Drum	79	Ball Bearing(2 Req.)
36	Belt	80	Bull Gear Pinion Counter Shaft
38	Timing Pulley Clutch Sleeve	81	Key
39	Splined Gear Hub	82	Wave Spring Washer
40	Spindle Bull Gear Assembly	83	Bull Gear Pinion
41	Ball Bearing(2 Req.)	84	Bull Gear Pinion Bearing Cap
42	Snap Ring(2 Req.)	85	Socket HD Cap Screw(2 Req.)
43	Bull Gear Bearing Spacer	86	Timing Belt Pulley
45	Vert. Tee Bolts(3 Req.)	87	Jam Nut
46	Steel Washer(3 Req.)		

VARIABLE SPEED HEAD BACK GEAR

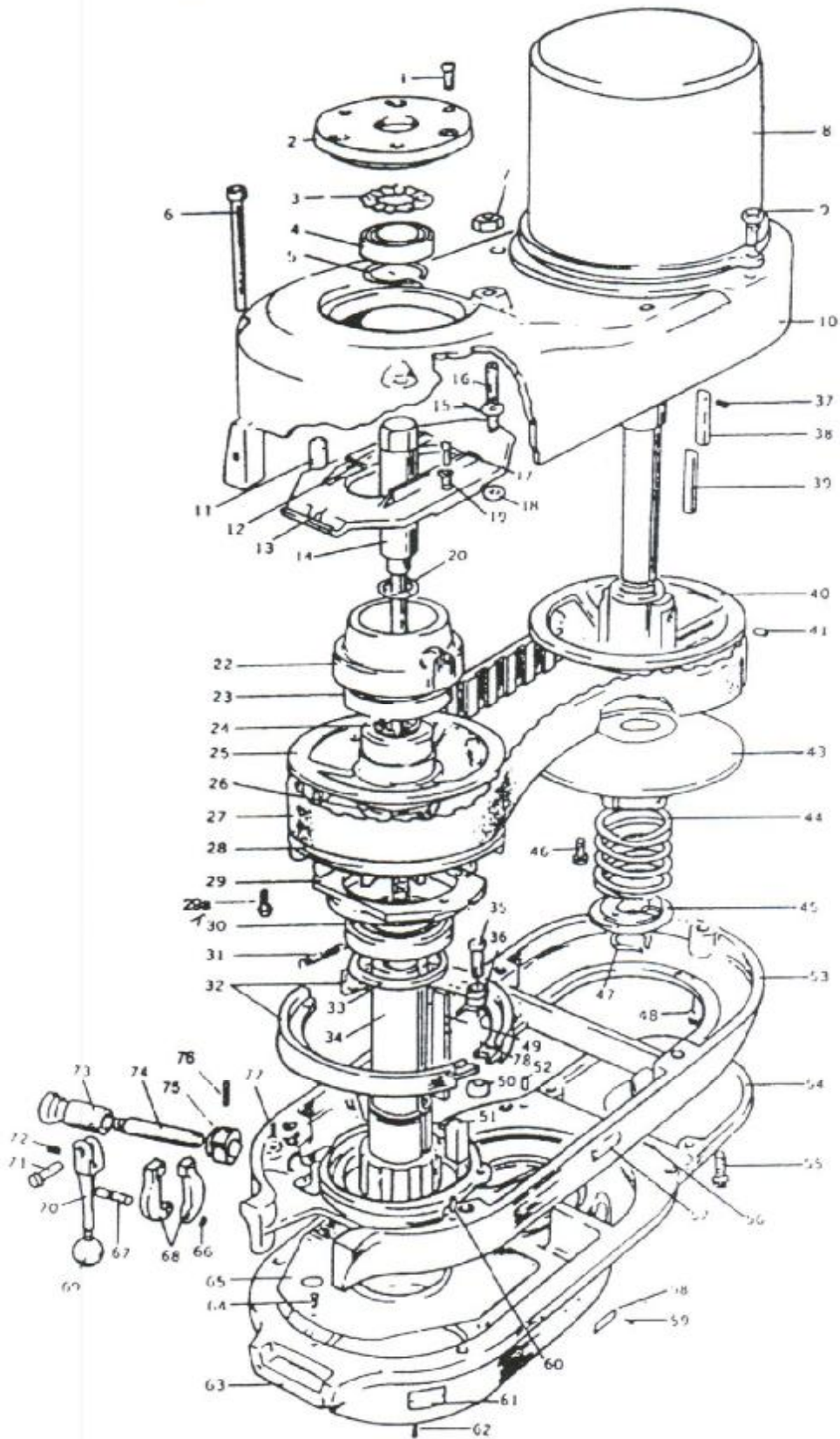

VARIABLE SPEED HEAD BACK GEAR

ITEM NO.	DESCRIPTION	ITEM NO.	DESCRIPTION
1	Socket Cap Screw(3 Req.)	40	Stationary Motor Varidisc
3	Spring Washer	41	Socket Set Screw
4	Ball Bearing	42	Plastic Insert(2 Req.)
5	Snap Ring No.	43	Adjustable Motor Varidisc Assembly
6	Socket HD Cap Screw(2 Req.)	44	Spring for Varidisc Motor Shaft
7	Hex Jam Nut	45	Adjustable Varidisc Spring Collar
8	Motor 2HP(complete unit)230/460/3/60	46	Socket HD Cap Screw(2 Req.)
9	Hex HD Screw(2 Req.)	47	Ret. Ring
10	Belt Housing	48	Socket Cap Screw
13	Speed Change Plate	49	Plastic Key
14	Drawbar	51	Key
15	Cotter Pin	52	Taper Pin
16	Speed Change Plate Pivot Stud	53	Belt Housing Base
17	Socket HD Cap Screw(2 Req.)	54	Motor Pulley Cover
18	Washer	55	Socket Cap Screw
19	Pivot Sleeve(2 Req.)	58	HI - LOW Range Nameplate
20	Draw Bar Washer Draw Bar Washer	59	Drive Screw(4 Req.)
22	Spindle Pulley Bearing Sliding Housing	60	Taper Pin(2 Req.)
23	Ball Bearing	61	Quill Feed Nameplate
24	Plastic Insert(2 Req.)	62	Rivets(4 Req.)
25	Adjustable - Driven Varidisc	63	Gear Housing
26	Snap Ring No.	64	Round HD Machine Screw(3 Req.)
27	Belt	65	Gear Housing Plate
28	Stationary Driven Varidisc	66	Snap Ring
29	Brake Bearing Cap	67	Brake Finger Pivot Stud
29a	Socket HD Cap Screw(2 Req.)	68	Brake Operating Finger
30	Ball Bearing	69	Bakelite Ball Handle
31	Brake Spring(2 Req.)	70	Brake Lock Hnadle
32	Brake Shoe Assembly(2 Req.)	71	Brake Lock Pin
33	Spindle Pulley Spacer	72	Socket Set Screw
34	Spindle Pulley Hub	73	Sleeve for Brake Lock Shaft
35	Hex HD. Screw	74	Brake Lock Shaft
36	Brake Shoe Pivot Sleeve	75	Brake Lock Cam
37	Roll Dowel Pin	76	Roll Pin
38	Drive Key	77	Socket Set Screw
39	Key for ADJ Varidisc Motor Shaft		

CENTRAL LUBRICATING OIL - FEEDING EQUIPMENT

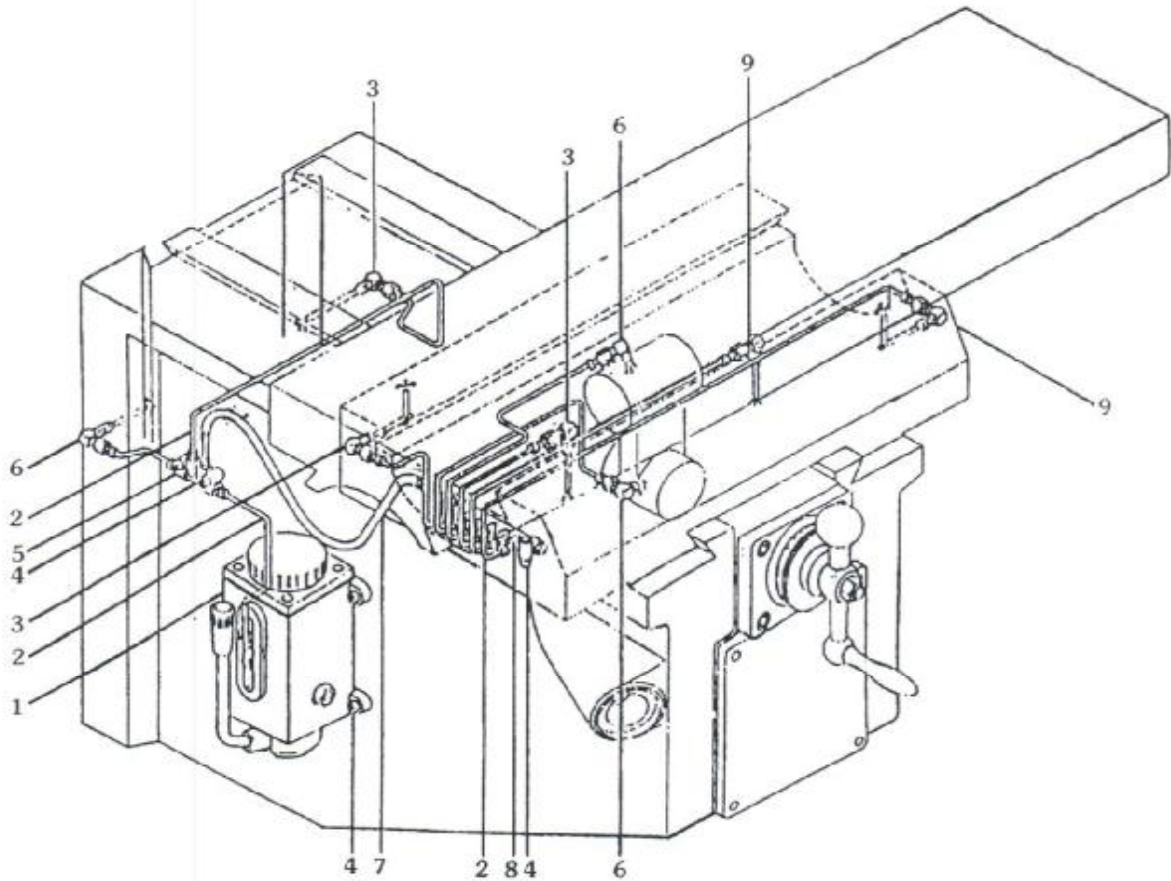

ITEM NO	DESCRIPTION	ITEM NO	DESCRIPTION
B001	Hand Oiler	E006	Ratio Oil Distributor CPS3(3 sets)
B002	Aluminum Pipe $\phi 4$	E007	Outside Steel Flexible Tube
B003	Ratio Oil Distributor CPS4(3 sets)	E008	A Type Oil Distributor A8
B004	Inhexagonal Screws	E009	Ratio Oil Distributor CPS5(2 sets)
B005	A Type Oil Distributor A4		

“GMC”

KNEE MILL

MODEL # GMM-949V

Operation and parts manual

“IMPORTANT SAFETY INSTRUCTIONS”

READ ALL INSTRUCTIONS BEFORE USING THE MACHINE

WARNING – TO REDUCE THE RISK OF ELECTRIC SHOCK, OR INJURY TO PERSONS:

1. The machine should never be left unattended when powered on.
2. Always shut down the power before changing any electrical and mechanical parts.
3. Close attention is necessary when the machine is used by or near other persons.
4. Never leave any chuck keys or tool holder clamps on the spindle and chucks before the machine turns.
5. Very carefully and properly install on all chucks, tool holder and clamps. Must tighten them up very heavily. Please double check very carefully and re – tighten them up although they are ready installed on when you receive the machine.
6. Use the machine only for its intended use as described in this manual. Use only accessories recommended by the manufacturer as contained in this manual.
7. Flying parts may result in eye and body injury. Never operate the machine without proper eyes and body protection.
8. Bodily injury could occur. Never place your hands or any part of your body in the machine.

LIFTING THE MACHINE

Note position of ram and table when lifting with sling.

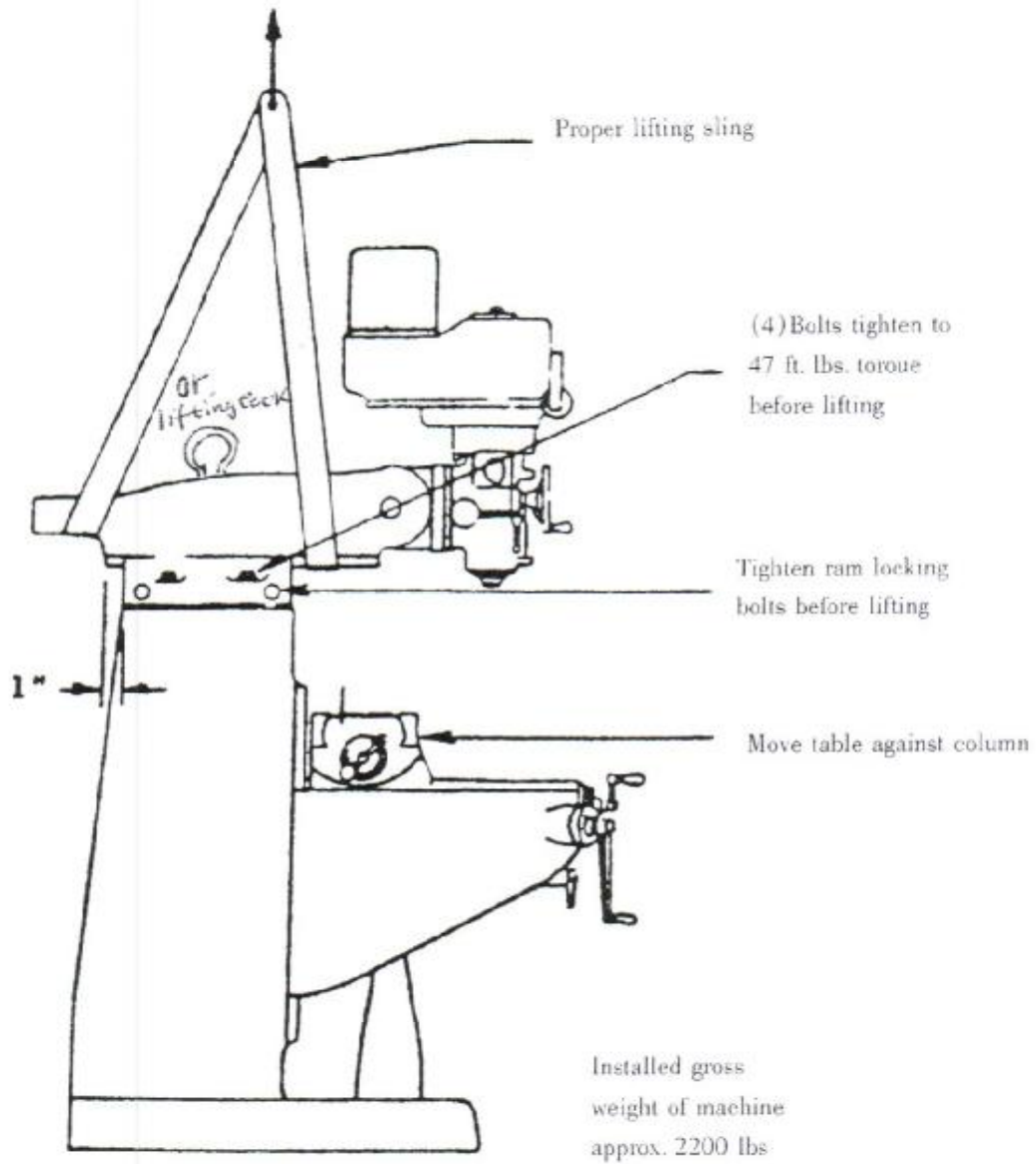

ALIGNMENT OF HEAD

In case of precision boring or work of that nature, where it is necessary to have head perfectly square with the table, use method prescribed below. For general milling use, graduations provided on the head are close enough. To set head perfectly square with table, see Figures 3 and 4. This may be done with Ram adapter (# 2 page 26) on Ram (# 10 page 26), by adjusting Ram adapter through vertical adjusting worm shaft (# 8 page 26). Loosen four locknuts (# 157 page 34) but leave drag on same for fine adjustment. To square head to table in the longitudinal axis, mount indicator as shown in Figure 4.

NOTE

WHEN INDICATING AS IN FIGURE 3. IT SHOULD BE NOTED THAT THE TABLE IS FITTED TO BE SLIGHTLY HI FRONT, USUALLY ABOUT .0.005"

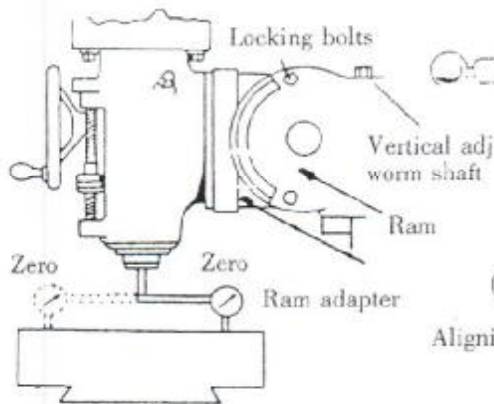

Figure 3. Head Alignment Y Axis

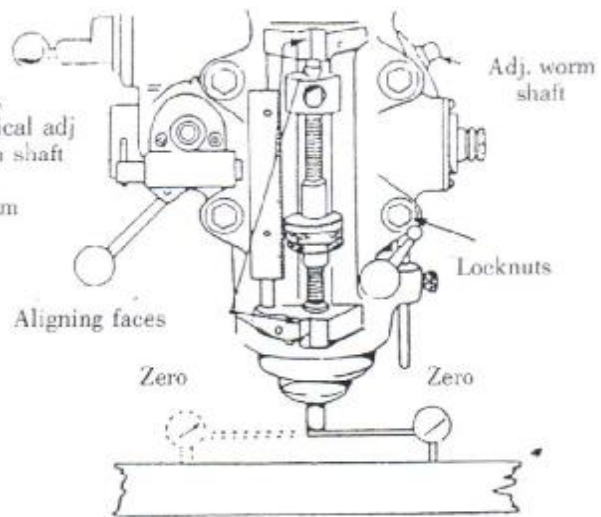

Figure 4. Head Alignment X Axis

LUBRICATION

Do not operate machine until properly lubricated. Lubrication of head is obtained by use of the drip feed method through two oil cups located at right side of belt housing. with light machine oil such as Socony D. T. E. light or equivalent.

ADJUSTMENT OF TABLE GIB. The table is provided with a full length tapered gib (# 43page26) in the saddle, and an adjusting screw on the left side . To take up gib, tighten gib adjusting screw (# 41page 26)slightly and repeat until a slight drag is felt when moving the table by hand .

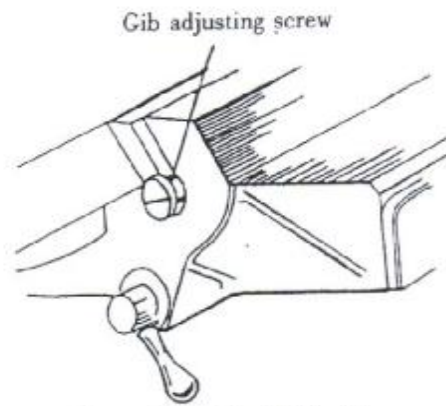
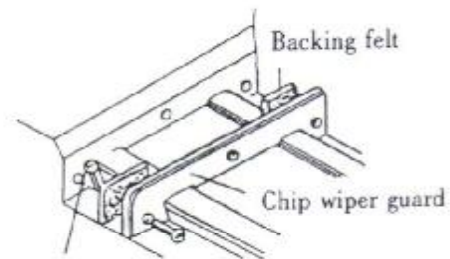

Figure 5. Saddle/Table Gib
(# 43 page 25)

ADJUSTMENT OF SADDLE AND KNEE GIBS. A tapered gib (# 49page26) is used for adjusting the saddle bearing on the knee. This forms a guide for the saddle . To tighten gib, the same principal as described above is used; however, the chip wiper has to be removed first.



Saddle gib adj. screw

Figure 6. Saddle - knee gib
(# 49 page 25)

ADJUSTMENT OF KNEE GIB. Remove chip wiper and adjust screw until smooth movements attained.

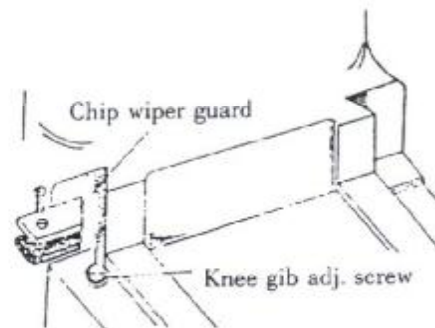
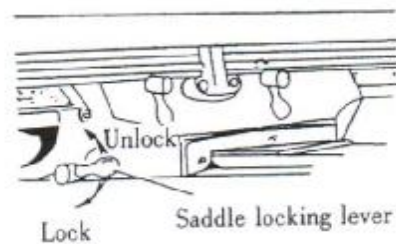

Figure 7. Knee - Column gib
(# 55 page 25)

CLAMPING TABLE, SADDLE AND KNEE. When milling with longitudinal table feed only, it is advisable to clamp the knee to the column and the saddle to the knee to add rigidity to these members and provide for heavier cuts with a minimum of vibration. The saddle locking lever is located on the left-hand side of saddle.



Excessive pressure can cause slight table bind. Use moderate clamping pressure, as this will hold saddle sufficiently.

The table clamp lever is located on front of saddle and should always be clamped when longitudinal movement is not required.

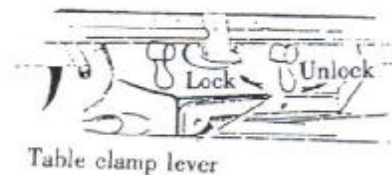

The knee clamping lever is at the left side of the knee and should be drawn upward to clamp the knee. This is only a tension brake and will not lock the knee completely. Leave clamped at all times unless using knee in operation.

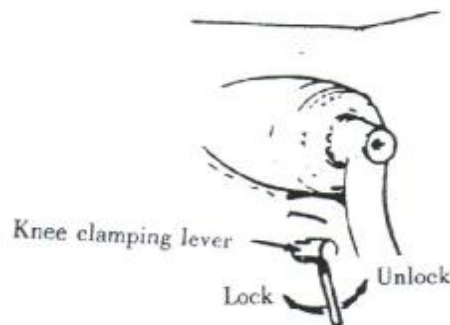

REMOVING TABLE Remove as follows: ball crank handles, dial holders, bearing brackets. Lead screw will then turn all the way out so it can be removed. When this is accomplished, the table can easily be taken off by sliding it from the saddle. See Figure 8.

REMOVING SADDLE. Follow along the same lines as removing table; however, it is necessary to remove the entire front bracket assembly. Next, remove the cross feed nut bracket which is made accessible by removal of the table. See Figure 8.

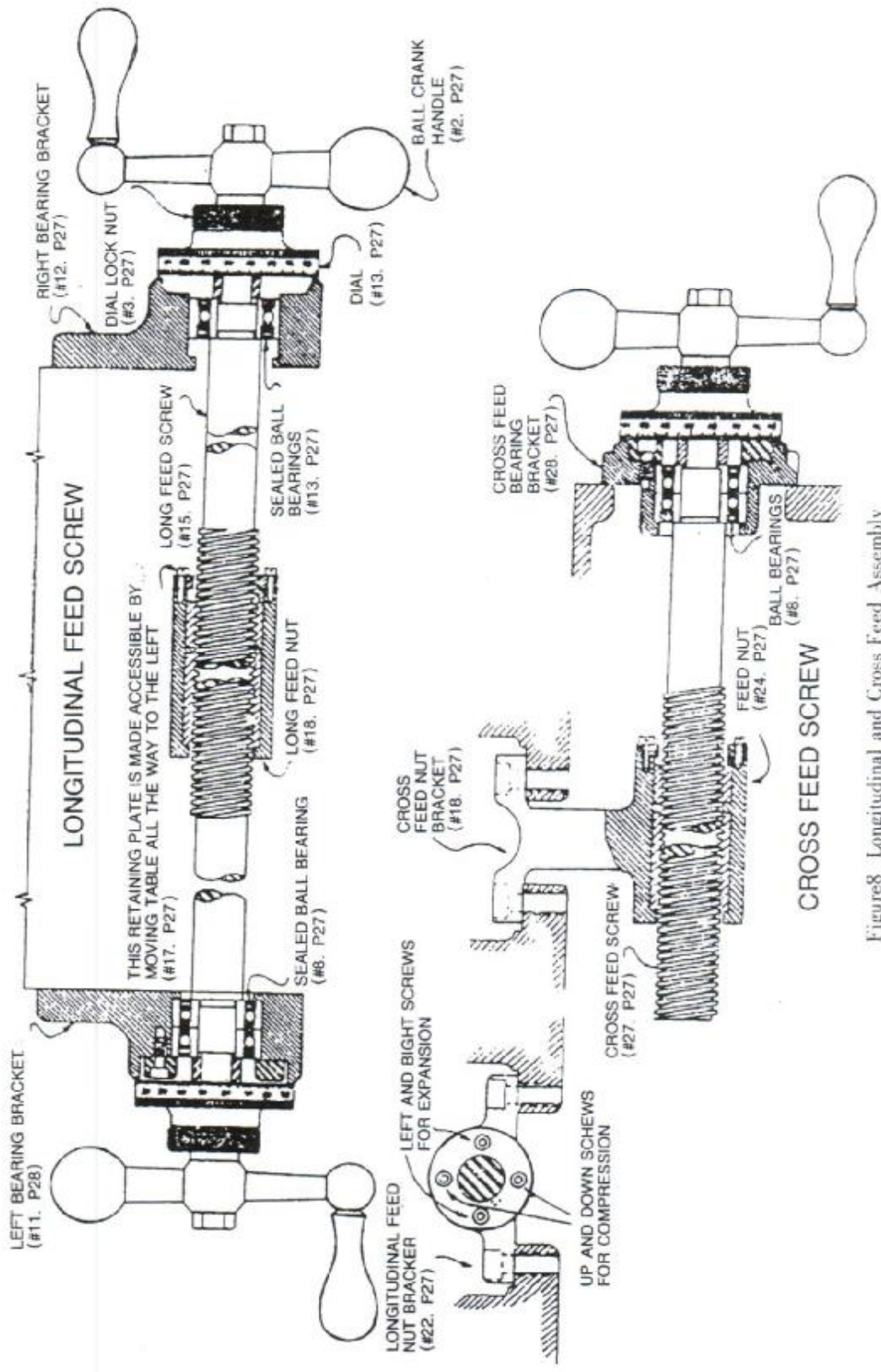

Figure 8 Longitudinal and Cross Feed Assembly

**ASSEMBLY INSTRUCTIONS
FOR MOUNTING DRIVE ATTACHMENT TO RAM ADAPTER**

Lift the attachment. Insert the four tee bolts into the ram adapter and position them to match the bolt holes in the attachment.

Slide the attachment onto the bolts, insert the spacers and washers and secure with the nuts.

Tighten all the nuts with 25 ft. lbs. of torque, and then repeat with 50 ft. lbs.

<p>CAUTION IMPROPER TIGHTENING OF THESE COULD CAUSE A CHOPPY QUILL MOVEMENT</p>
--

LUBRICATION:

The useful life of this attachment will be determined to a large extent by proper lubrication. Carefully observe the nameplate recommendations and avoid substitutions.

OPERATING INSTRUCTIONS:

SPEED CHANGE HANDWHEEL (16, Figure 9): DO NOT attempt to change spindle RPM unless the motor is running. Dial speeds will only be approximate. Belt wear will cause a slight variation in speeds from what is indicated on the dial.

When tightening or loosening the drawbar(# 14 Page 38)it is necessary to lock the spindle. To accomplish this, use the spindle brake (3) which is located on the left side of belt housing, turning it either to the right or left until it binds, then raise the quill feed handle (13).

Drawbar(# 14 page 38) has 7/16 - 20 right hand thread and should be tightened with normal amount of pressure using wrench furnished with machine. To loosen collet back off drawbar and if collet does not open immediately give knob on top of drawbar a slight tap. Spindle has non - sticking taper and collet should release readily.

VARIABLE SPEED HEAD

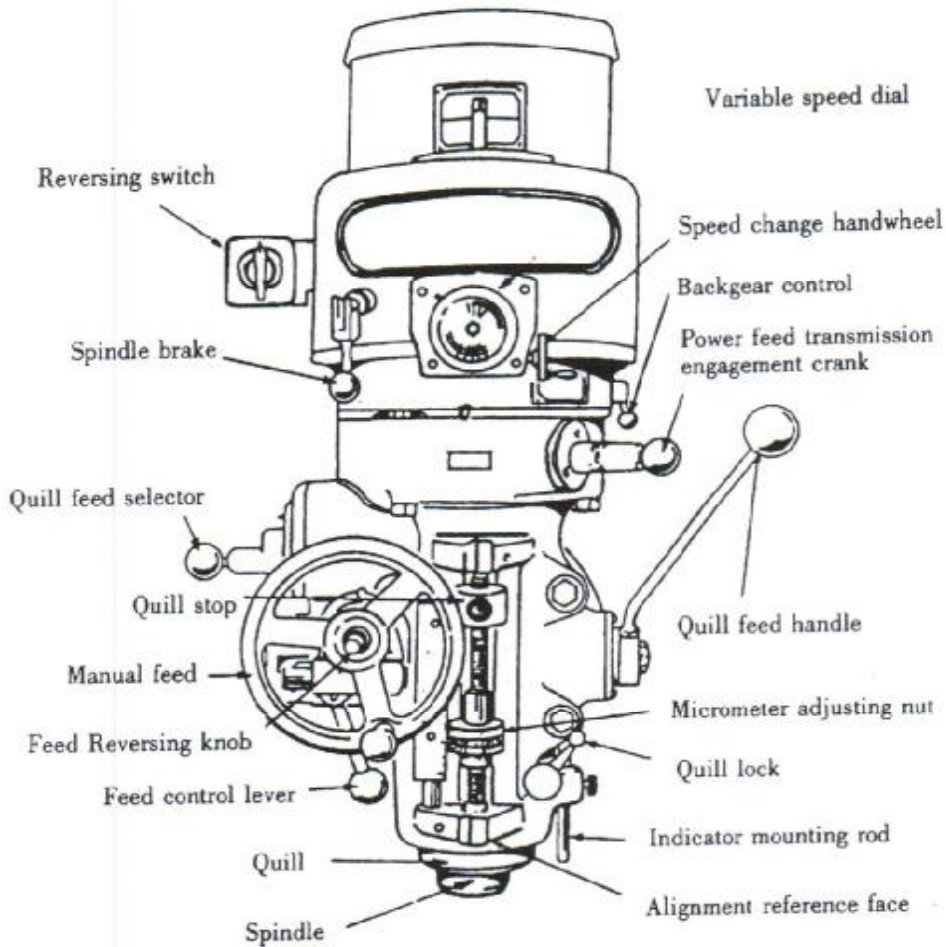

- * Spindle Speed Range
90 - 4000RPM 3HP Optional
- * Quill Power Feed
.0015, .003, .006" Inch / .04, .08, 0.15mm/rev.
- * Quill Travel
5" Inch / 127mm
- * Quill Diameter
3.3/8" Inch / 85.725mm
- * Spindle Taper
R.8 or ISO 30
- * Spindle Motor
3HP Optional

ADDITIONAL FEATURES

- * Spindle Straightness
Along 12" Inch / 300mm and .90° 0.004" Inch / * .01mm
- * Spindle Nose Taper I. D., .0002" kbcg / 0.005mm TIR
- * Hard Chrome Quill

SPINDLE BRAKE (3. Figure 9):

Brake lever can be moved in either direction to stop spindle. When locking spindle, lever should be moved right or left and then raised. There are no adjustments on brake so it must be replaced when worn out:

CAUTION
BE SURE THAT THE SPINDLE BRAKE IS RELEASED
BEFORE STARTING THE MOTOR. THIS IS IMPORTANT
AS THE MOTOR CAN BE DAMAGED IF SWITCH IS TURNED
ON WITH BRAKE IN LOCKED POSITION.

FORWARD - REVERSE SWITCH(# 1. Fig. 9):

This is the motor reversing switch. When the head is direct drive (High Range), the motor and spindle are turning the same direction. When the head is in "Back Gear" (Low Range), the spindle runs backwards unless the motor direction is reversed.

HI - NEUTRAL - LO LEVER(# 15, Fig. 9):

The lever is used to put the head into either direct drive or backgear. Rotate the spindle by hand to facilitate meshing of clutch or gears.

Neutral can be obtained at mid - way position, and is provided to permit free spindle rotation for indicating and set - up.

After an extended period of use, the neutral position may cause noise by allowing the clutch teeth to rub each other. This can be corrected by loosening set screw (# 64, page 6) . and reversing the position of the detent plate (# 65, page 36) .

In high speed (Direct Drive), the spindle is driven by tapered clutch teeth. If the clutch is not meshed tightly, clutch rattle will be heard. This can be corrected by moving the detent plate upward as the clutch wears. This is also the reason for possible loss of neutral, requiring the reversal of the detent plate.

CAUTION
DO NOT shift Hi - Lo Lever while motor is running.

POWER FEED TRANSMISSION ENGAGEMENT CRANK (4. Figure 9): Engages power feed worm gear. When lever is in right hand hole, the power feed worm gear is engaged. To disengage worm gear, pull knob out and crank handle in clockwise or down direction and move to opposite position.

NOTE
CRANK CANNOT BE SWUNG AROUND IN COUNTER CLOCKWISE DIRECTION;
HOWEVER, NO DAMAGE WILL OCCUR IF MOVED IN THIS DIRECTION. TO
ENGAGE THE WORM A CLOCKWISE MOVEMENT IS REQUIRED.

CAUTION

POWER FEED WORM GEAR MAY BE ENGAGED WHEN SPINDLE IS ROTATING, HOWEVER, IT SHOULD BE ENGAGED GENTLY TO AVOID DAMAGE TO WORM GEAR. THE WORM GEAR MAY BE DISENGAGED AT ANY TIME. DO NOT USE POWER FEED AT SPEEDS ABOVE 3000 RPM.

IMPORTANT: It is recommended that the Power Feed worm gear be disengaged whenever the power feed is not required. This will avoid unnecessary wear on power feed worm gear.

QUILL FEED SELECTOR (5): This crank is used for selecting the three feeds; .0015", .003" and .006" per revolution. It is shifted by pulling knob out and turning from one position to the other. Feeds are stamped on cover below indentation hole. Feed is more readily engaged when spindle is running.

FEED REVERSE KNOB (7): Position of this knob depends upon direction of spindle rotation. If boring with right hand cutting tools, pull feed handle towards operator until clutch becomes engaged.

Neutral position is between forward and reverse position. It is recommended that the handle be left in neutral position when not in use.

MANUAL FEED HANDWHEEL (6): Feed reversing knob should be in neutral position and feed control lever (8) engaged. Clockwise rotation of handwheel moves quill down. The Manual Feed Handwheel and the Quill Feed Handle may be disengaged by moving them outward about .8"

NOTE

The feed control lever must be engaged in order to use manual feed controls. The Quill Feed Handle and Manual Feed Handwheel may be taken off when not in use.

FEED CONTROL LEVER (8): Engages over-load clutch on pinion shaft when positioned left and will stay engaged until either quill stop comes in contact with micrometer adjusting nut, forcing feed control lever to drop out automatically, or released manually by engaging lever to right.

NOTE

The Feed Control Lever is carefully set at plant to disengage automatically when quill stop goes against micrometer adjusting nut or against throw out pin at top. However, if this should go out of adjustment, it may easily be brought back by regulating the socket set screw located at bottom of tripping rod (item no. 144 page 35).

CAUTION

WHEN ADJUSTING THE SOCKET SET SCREW, CHECK AUTOMATIC DISENGAGEMENT IN BOTH DIRECTIONS; THAT IS WITH QUILL - STOP NUT (# 161 PAGE 35) AGAINST THE FEED TRIP LEVER (# 145 PAGE 35) FOR DOWN POSITION, AND AGAINST REVERSE TRIP BALL LEVER (# 183 PAGE 35) FOR THE UPPOSITION.

QUILL FEED HANDLE (13): May be removed by simply pulling handle off. It is recommended that handle be disengaged when using power feed.

QUILL STOP KNOB (14): Is used to disengage automatic feed in either direction as well as the setting point for working to given depths.

MICROMETER NUT (11): This nut is used for setting of depths. Each graduation on nut indicates .001" of depth, it reads directly to scale mounted along side of it. Depths may be obtained by setting micrometer nut in conjunction with quill stop.

QUILL LOCK (12): This is a friction quill lock to be used when quill is in stationary position such as milling operations. It is recommended that this lock be used whenever quill movement is not desired.

POSITION OF RAM: Can be regulated by loosening two Ram Lock Studs (# 119 page 26) on turret (# 124 page 26) and pulling the ram (# 10 page 26) in or out to desired position.

CAUTION
CARE SHOULD BE TAKEN TO LOCK RAM
SECURELY AFTER SETTING.

NOTE
It is recommended that on heavy milling work, head, should be kept
as close to column as possible, where maximum rigidity is obtained.

RECOMMENDATIONS:

Use 2, 3, or 4 flute end mills. Eight flute end mills are usually not as satisfactory for general milling. When using shell mills, face mills or any other tooling, proper machining practice should be observed.

Power feed can be used for drills up to 3/8" in diameter. Use manual feed for drills larger than 3/8"

Overload clutch is set at factory to hold up to 200 lbs down pressure on quill, which will accommodate drills up to 3/8" diameter in mild tool steel.

CAUTION
THIS CLUTCH SHOULD NOT BE TAMPERED
WITH IN THE FIELD.

OPERATING INSTRUCTIONS

CAUTION
DO NOT TRY TO CHANGE SPEED POSITION
UNTIL MOTOR IS RUNNING. THIS COULD
CAUSE BREAKAGE OF PARTS.

Spindle Speeds are adjusted by turning speed change handwheel(# 21 page 36) on the front of the belt housing. There are two ranges shown;60 to 500 and 500 to 4200.

60 to 500 is obtained through the back - gear drive and is referred to as the low range. To engage the back - gears, use the lever marked Hi - Neutral - Lo on the right rear side of the attachment. Move this lever to the "LO" position and use the low range on the down switch.

when shifting to "LO" DO NOT FORCE THE LEVER if the back gears do not mesh. Hold the lever so that the gears are clear of one another, rotate the spindle nose by hand until the gears line up, then put the unit in "LO"(back gear).

500 to 4200 RPM is obtained through direct drive and is the high range. The same lever and switch as above are used; selecting the "HI" range.

When shifting to "Hi" do not force the lever if the clutch teeth do not mesh. It is a simple matter to engage the brake and rotate the spindle nose by hand until the clutches engage.

Wear on the vari - drive belt will cause a slight change in the speeds to that shown in windows(# 23 page 36) on the dial. this can be corrected as follows. Crand the speed change handwheel(# 16, Figure 9) snugly against the high speed stop. (This will be near the 4200 reading on the dial.) Use a tachometer to determine the spindle speed, then turn the pivot stud(# 16 page 38), after loosening the jam nut(Item # 7 page 38) until the spindle speed registers 4200 on the tachometer; tighten jam nut.

Now reposition the speed dial plate to match the tachometer reading. This is done by loosening the Hex nut (# 1 page 36) until the spindle speed registers 4200 on the tachometer; tighten jam nut.

CAUTION

**TRY TO AVOID SHIFTING THE HI - LO LEVER
WHEN THE FEED WORM IS ENGAGED.**

DO NOT LOOSEN the 3 hex nuts(# 61 page 36) on the upper part of the Quill Housing(# 192 page 34). These are set at the factory and are used only for alignment.

SWIVELING THE VARI - DRIVE may be accomplished by loosening the lower 3 hex nuts(# 47 page 36) attaching the Vari - drive unit to the quill housing and then swiveling to any desired position. See arrangement of T - Bolts(# 45 page 36) in Gear Housing(# 63 page 36) for this purpose.

WARNING

**CARE MUST BE TAKEN TO SECURE THE NUTS
(# 47 page 36) WHEN THE ATTACHMENT IS IN
POSITION, BEFORE THE MOTOR IS TURNED ON.**

REMOVING THE MOTOR(See Figure 10): Run the attachment to the bottom of either speed range and shut off the motor. This puts the vari - drive belt in the best position for disassembly.

1. DISCONNECT THE POWER and then remove the switch from the side of the belt housing.
2. Remove the cover (# 54 page 36) (B, Figure 10) at the lower end of the motor shaft. Use two cover screws (# 55 page 36) (A) to fasten the spring (# 44 page 38) (C) on the lower end of the motor shaft, to the lower motor vari-drive pulley (# 43 page 38). This will reduce the hazard of personal injury that is always present when a heavy spring is under compression. When the pulley, spring retainer (# 45 page 38) and spring are securely fastened as a single unit, crank the speed change handwheel (# 16 Figure 9) to top speed position.
3. Now remove the screws (# 9 page 38) (D) that fasten the motor to the belt housing the motor should be lifted slightly and pulled firmly away from the spindle and toward the rear of the belt housing. This will pull the Vari-drive belt (# 27 page 38) deeply into the spindle pulley (# 25 page 38), providing the slack needed to slip the belt over the motor pulley (# 43 page 38).
4. Now lift the motor high enough to rest the motor base GENTLY on the adjusting screw (# 16 page 38) (E) seen directly in front of the motor flange. The belt can now be slipped over the lower pulley and the motor removed from the housing.

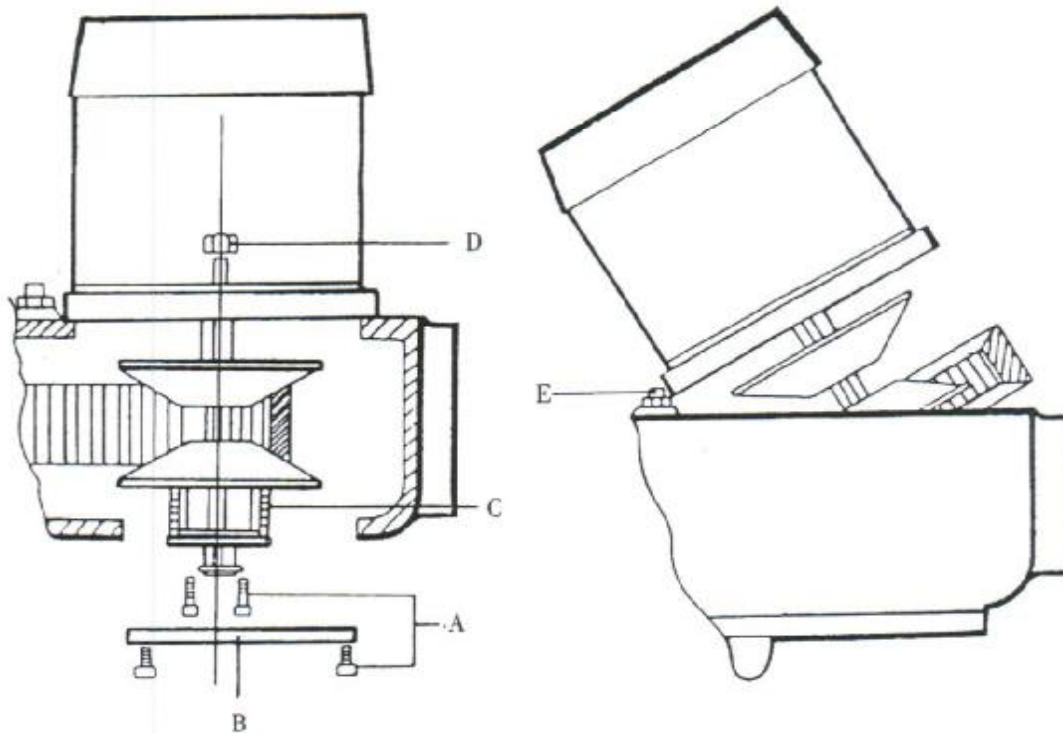

Figure 10. Removing the Motor (Side View)

CHANGING VARI- DRIVE BELT (Figure 11)

Complete the above procedures for removing the motor, then remove the three screws (# 1 page 38) (A, Figure 11) and lift out the top bearing cap move two socket head cap screws (# 17 page 38) and sleeves (# 19 page 38) (C). Next, remove the four screws (# 6 page 38) (D) and the screw (# 55 page 38) (E) holding the belt housing (G) to the base (# 53 page 38). Unscrew and remove the two lower screws (# 25 page 36) in the speed changer bracket just below the speed dial (# 2 page 36) (F).

NOTE

On Models with plastic face plate (# 23 page 36) remove screws (# 22 page 36) first.

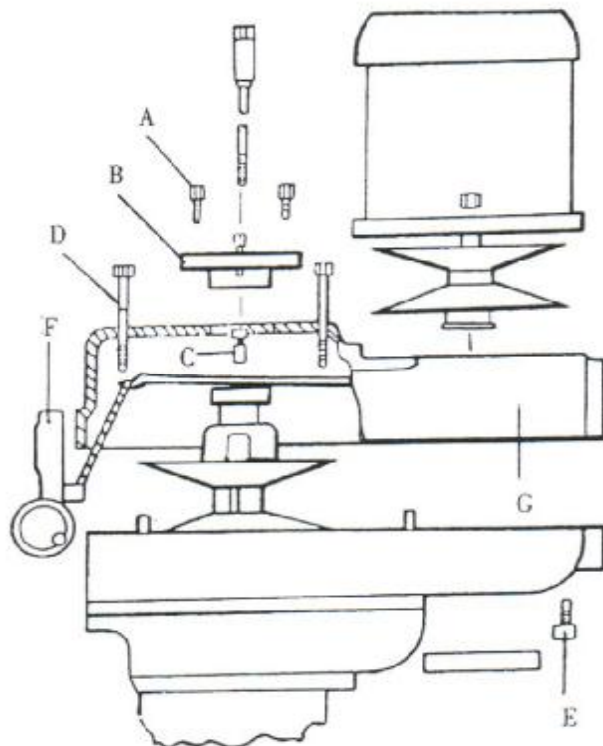

Figure 11. Removing the Vari - Drive Belt

The belt housing, complete with speed changer bracket, is now removed from its belt housing base (# 53 page 38). A slight blow under the speed changer bracket (# 5 page 36) may be needed to separate the belt housing (# 10 page 38) from the belt housing base (# 53 page 38).

Remove the old belt (# 27 page 38) and replace it with a new belt. DO NOT use a substitute belt purchased from other than a Bridgeport Dealer. Vibration and heat could result from the use of the wrong belt.

CHANGING TIMING BELT (Figure 12)

Complete the operation for removing the motor. Then put the Hi - Neutral - Lo lever (# 15, Figure 9) in the Lo position, remove the drawbar (# 14 page 38) (A, figure 12) and lower the spindle.